

NOTES:

1. Rating: 300V 13.5A (IEC 250V) \triangle
- PITCH: 5.08mm
2. Insulation Withstands Voltage: AC 1500 V/MIN
3. Insulation Resistance: 500M Ω or more at DC500V
4. Using Temperature Range: -40°C~+105°C
5. Screw Torque Value: ~~5.5kgf-cm~~ \triangle
6. Suitable Electric Wire: ~~AWG 26~18~~ \triangle

7. Undimensioned Tolerances:

—	\curvearrowright	\square	0.05/10
\perp	\parallel	\equiv	0.2/10
UNDIMENSIONED TOLERANCES			±0.3

8. 表面處理為鉻噴沙

P	4	6	8	10	12	14	16	18	20	22	24	26
U	5.08	10.16	15.24	20.32	25.40	30.48	35.56	40.64	45.72	50.80	55.88	60.96
V	10.16	15.24	20.32	25.40	30.48	35.56	40.64	45.72	50.80	55.88	60.96	66.04
P	28	30	32	Tolerances for PITCH ERROR								
U	66.04	71.12	76.20									
V	71.12	76.20	81.28									

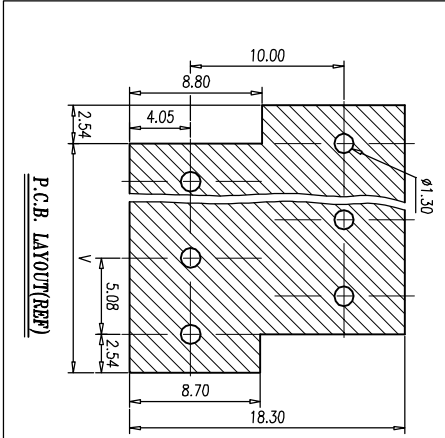

\triangle	工程變更	H J	06.04.24	CHK.	DINKLE	DWG NO.	SP-02-EELK508V
\triangle	工程變更	YFY	03.12.30	APP.	DINKLE	NAME	EELK508V-□□P
\triangle	工程變更	YFY	02.12.27	DATE	DINKLE	NAME	EELK508V-□□P
REV.	CONTENT	CHK.	DATE	DATE	DINKLE	NAME	EELK508V-□□P

5	SOLDER PIN	0068B00200	P/2	BRASS	Sn Plated
4	SOLDER PIN	0068B00100	P/2	BRASS	Sn Plated
3	WIRE CAGE	X000005400	P	STEEL	M2.5/Zn Plated
2	SCREW	S000025300	P	STEEL	M2.5/Zn Plated
1	HOUSING	0068L00000	1	PA66	GREEN

DWG.	梁紅英	DATE	01.07.11	UNITS	MM	SHEET/OF	1/1
SCALE	4:1	DATE					