

SECTION A-A

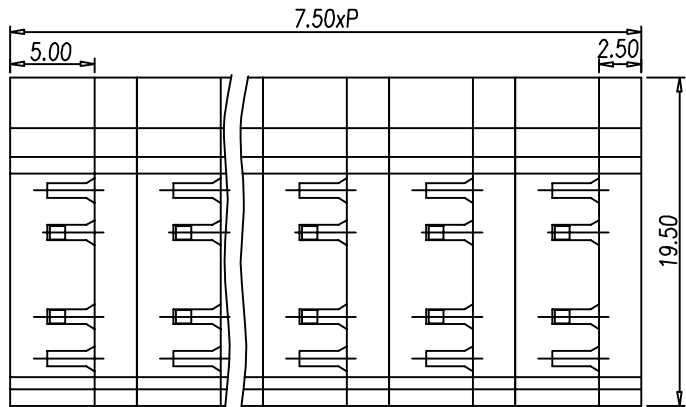

- NOTES: $\triangle 4$ 300V 26A Factory wrie $\triangle 4$
 300V 20A Field wrie (IEC 750V 24A)
 1. Rating: ~~300V 26A (IEC 250V 16A)~~
 PITCH: 7.50 mm
 2. Insulation Withstands Voltage:
 AC 2000V/MIN
 3. Insulation Resistance:
 500M Ω or more at DC500V
 4. Using Temperature Range:
 -40°C~+130°C
 5. Screw Torque Value: 5 kg-cm
 6. Suitable Electric Wire: AWG 22~12 (IEC 2.5mm²)
 7. Undimensioned Tolerances:

\pm	\sim	∇	0.05/10
\perp	\parallel	\equiv	0.2/10
PITCH ERROR			0.05/10
UNDIMENSIONED TOLERANCES			± 0.3

ITEM	NAME OF PART	NO. OF PART	Q'TY	MATERIAL	NOTES
7	SCREW	S000007000	P	STEEL	M2.5/Zn Plated
6	WIRE CAGE	0015B00600	P	STEEL	Zn Plated
5	SOLDER PIN	0015B00400	P	COPPER	Tin Plated
4	CAM	0015B00500	P	STEEL	Zn Plated
3	END COVER	0015A3XX00 0015A00500	$\triangle 3$ 1	PBT(G15)	GREEN
2	CENTER PIECE	0015A2XX00 0015A00400	$\triangle 3$ P-1	PBT(G15)	GREEN
1	HOUSING	0015A1XX00 0015A00300	$\triangle 3$ P	PBT(G15)	GREEN

$\triangle 4$	工程變更	HQH	05.12.12	DWG.	林浚宏	DATE	96.12.20	UNITS	MM	SHEET/OF	1/2
$\triangle 3$	工程變更	YFY	02.06.21	CHK.		DATE		SCALE	3:1 (:)	\oplus	\square
$\triangle 2$	產品更新	梁紅英	01.07.25	APP.		DATE		NAME	DT-123RA-□□P3		
$\triangle 1$	修正版面	蔣雪嬌	99.11.15								
REV.	CONTENT	CHK.	DATE	DINKLE ENTERPRISE CO.,LTD		DWG NO.	SP-02-123RAP30				